

Product information presented here reflects conditions at time of publication. Consult factory regarding discrepancies or inconsistencies.

PUMP COMPANY

Zoeller Family of Water Solutions™

MAIL TO: P.O. BOX 16347 • Louisville, KY 40256-0347
 SHIP TO: 3649 Cane Run Road • Louisville, KY 40211-1961
 (502) 778-2731 • 1 (800) 928-PUMP • FAX (502) 774-3624

visit our web site:
www.zoeller.com

**TURNKEY PREPACKAGED & JOB READY GRINDER SYSTEMS
 WITH SQUARE GUIDE RAIL SYSTEM
 MODEL 810 AND 815 PROGRESSING CAVITY PUMPS**



FIBERGLASS BASIN PACKAGE

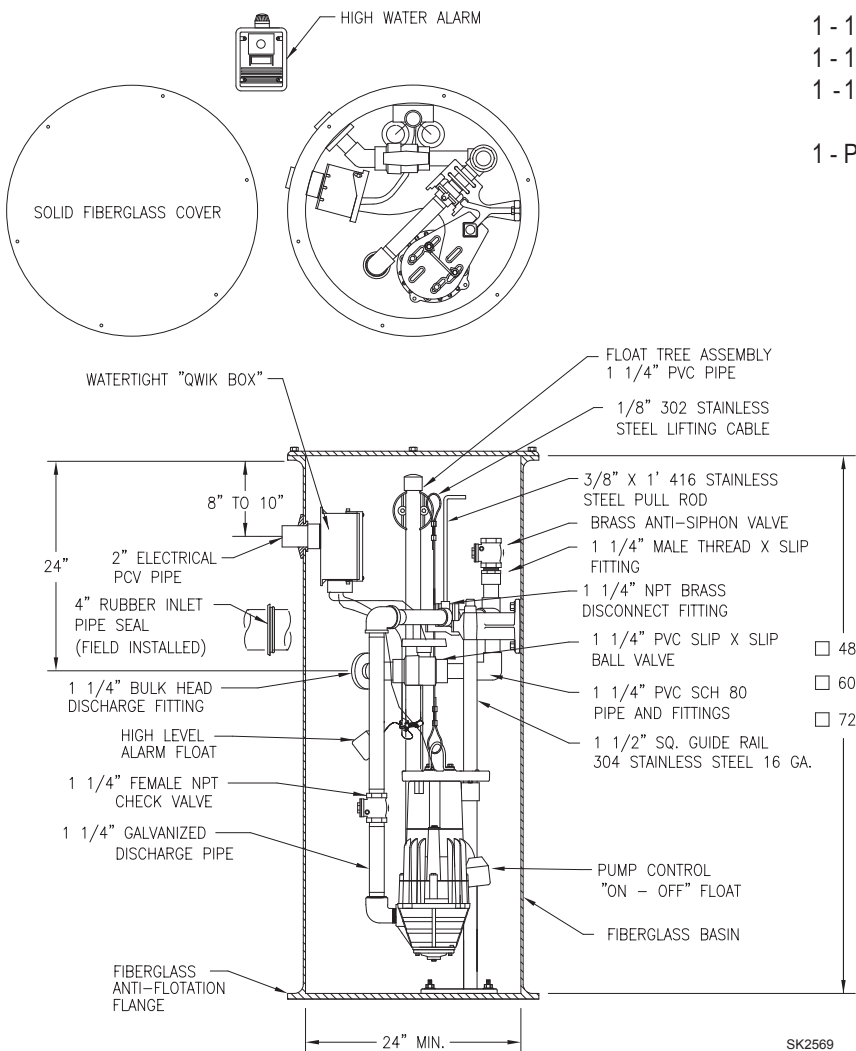

Fiberglass Basin Assemblies Include:

- 1 - Progressing Cavity Grinder Pump, 1 or 2 HP, 230 Volt, single phase, 20' cord
- 1 - 10-0035 Piggyback Float Switch, 230V/1Ph 13A w/15' cord
- 1 - 10-0580 Qwik-Box - NEMA 4X
- 1 - 10-0623 Indoor/Outdoor High Water Alarm w/15' Float Switch
- 1 - Packaged Basin Assembly including:
 - 24" Diameter Fiberglass Basin w/ Anti-flotation Device and Solid Fiberglass Cover
 - 1 1/4" Galvanized Discharge Piping
 - Square Guide Rail System
 - Float Tree
 - Check and Ball Valves
 - Anti-Siphon Device
 - Inlet, Discharge and Electrical Fittings
 - Stainless Steel Lifting Cable and Lifting Rod

ITEM NO.	PUMP	DESCRIPTION	VOLTAGE	AMPS	HP	WEIGHT
922-0025	E810	Simplex Progressing Cavity Grinder Package System - 24" X 48" FG	230V-1 Ph	7.0	1	296
922-0026	E810	Simplex Progressing Cavity Grinder Package System - 24" X 60" FG	230V-1 Ph	7.0	1	309
922-0027	E810	Simplex Progressing Cavity Grinder Package System - 24" X 72" FG	230V-1 Ph	7.0	1	323
922-0028	E815	Simplex Progressing Cavity Grinder Package System - 24" X 48" FG	230V-1 Ph	10.5	2	296
922-0029	E815	Simplex Progressing Cavity Grinder Package System - 24" X 60" FG	230V-1 Ph	10.5	2	309
922-0030	E815	Simplex Progressing Cavity Grinder Package System - 24" X 72" FG	230V-1 Ph	10.5	2	323

TURNKEY PREPACKAGED & JOB READY GRINDER SYSTEMS (Continued)

WITH SQUARE GUIDE RAIL SYSTEM

MODEL 810 AND 815 PROGRESSING CAVITY PUMPS

POLY RIBBED BASIN PACKAGE

Poly Ribbed Basin Assemblies Include:

- 1 - Progressing Cavity Grinder Pump, 1 or 2 HP, 230 Volt, single phase, 20' cord
- 1 - 10-0035 Piggyback Float Switch w/15' cord
- 1 - 10-0580 Qwik-Box - NEMA 4X
- 1 - 10-0623 Indoor/Outdoor High Water Alarm w/15' Float Switch
- 1 - Packaged Basin Assembly including:
 - 24" Diameter Poly Ribbed w/Blank Polyethylene Cover
 - 1 1/4" Galvanized Discharge Piping
 - Square Guide Rail System
 - Float Tree
 - Check and Ball Valves
 - Anti-Siphon Device
 - Inlet, Discharge and Electrical Fittings
 - Stainless Steel Lifting Cable and Lifting Rod

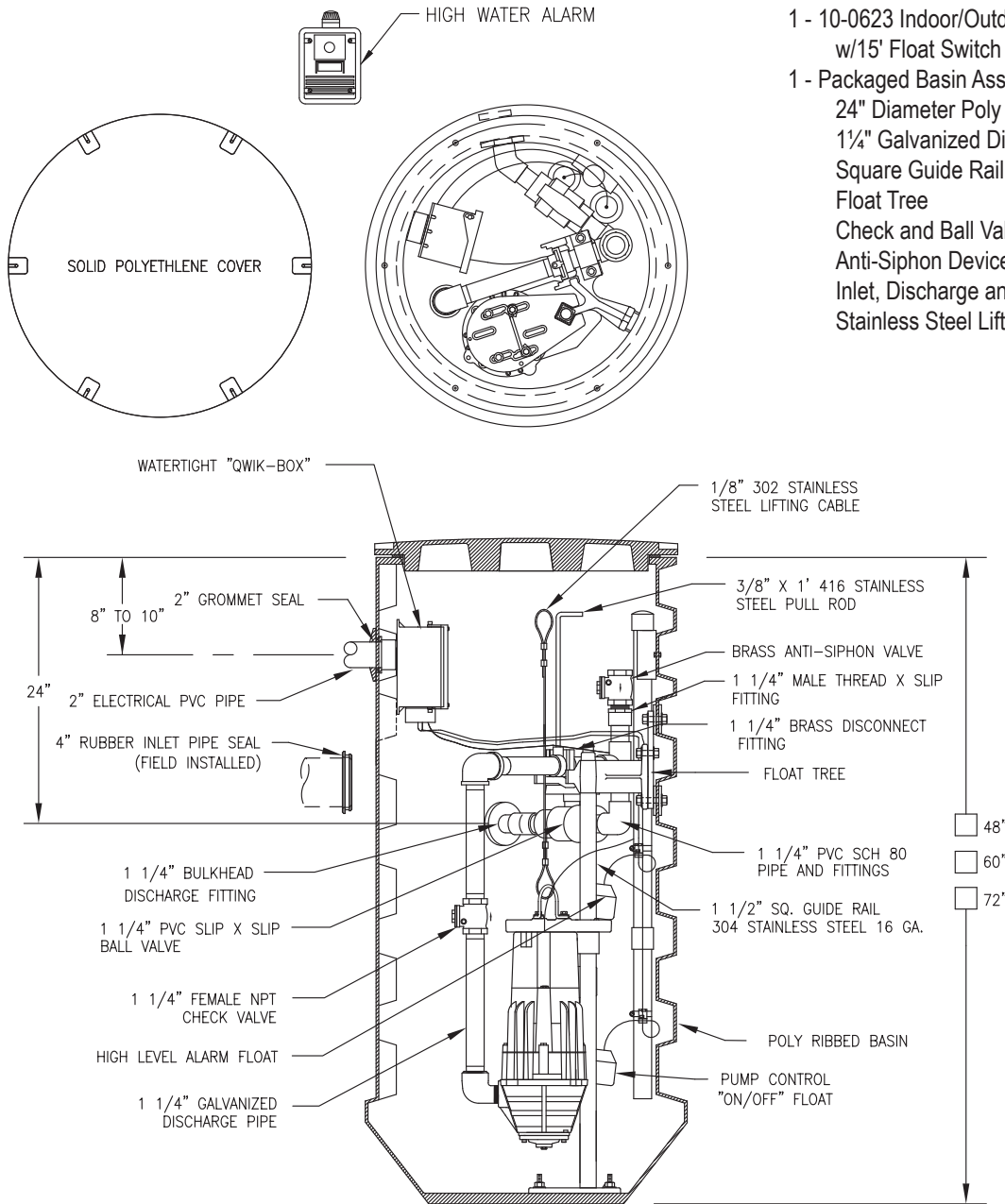

ITEM NO.	PUMP	DESCRIPTION	VOLTAGE	AMPS	HP	WEIGHT
922-0031	E810	Simplex Progressing Cavity Grinder Package System - 24" X 48" Poly	230V-1 Ph	7.0	1	299
922-0032	E810	Simplex Progressing Cavity Grinder Package System - 24" X 60" Poly	230V-1 Ph	7.0	1	314
922-0033	E810	Simplex Progressing Cavity Grinder Package System - 24" X 72" Poly	230V-1 Ph	7.0	1	320
922-0034	E815	Simplex Progressing Cavity Grinder Package System - 24" X 48" Poly	230V-1 Ph	10.5	2	299
922-0035	E815	Simplex Progressing Cavity Grinder Package System - 24" X 60" Poly	230V-1 Ph	10.5	2	314
922-0036	E815	Simplex Progressing Cavity Grinder Package System - 24" X 72" Poly	230V-1 Ph	10.5	2	320