

# Catalog Numbers, Features and Ratings

- 1 PHASE, 3 WIRE, 120/240V ~
- FEED-THRU TERMINALS FACTORY INSTALLED
- MAIN BREAKER: 200A, 22K AIC MAIN BREAKER FACTORY INSTALLED  
MAIN LUG: 100K AIC MAX. RATED  
(SEE WIRING DIAGRAM FOR DETAILS)
- CONVERTIBLE MAIN LUG/MAIN BREAKER
- TYPE 3R OUTDOOR ENCLOSURE
- ANSI 61 GRAY POWDER COATED ENCLOSURE
- DESIGNED FOR USE WITH PLUG-ON NEUTRAL BREAKERS



Catalog Number	ENCLOSURE DIMS (inside)			Amps Max	Number Spaces	Number Circuits	Bus Bar Material	Bus Bar Plating
	L	W	D					
PNW0816B1200TC	23.00	14.25	4.50	200	08	16	Copper	Tin Plated
PNW0816L1200TC	23.00	14.25	4.50	200	08	16	Copper	Tin Plated

**PNW0816B1200TC**  
Main Breaker Load Center

VIEWS SHOWN WITH DEADFRONT REMOVED AND DOOR OPEN

**PNW0816L1200TC**

Main Lug Load Center  
Same as Main Breaker except as shown

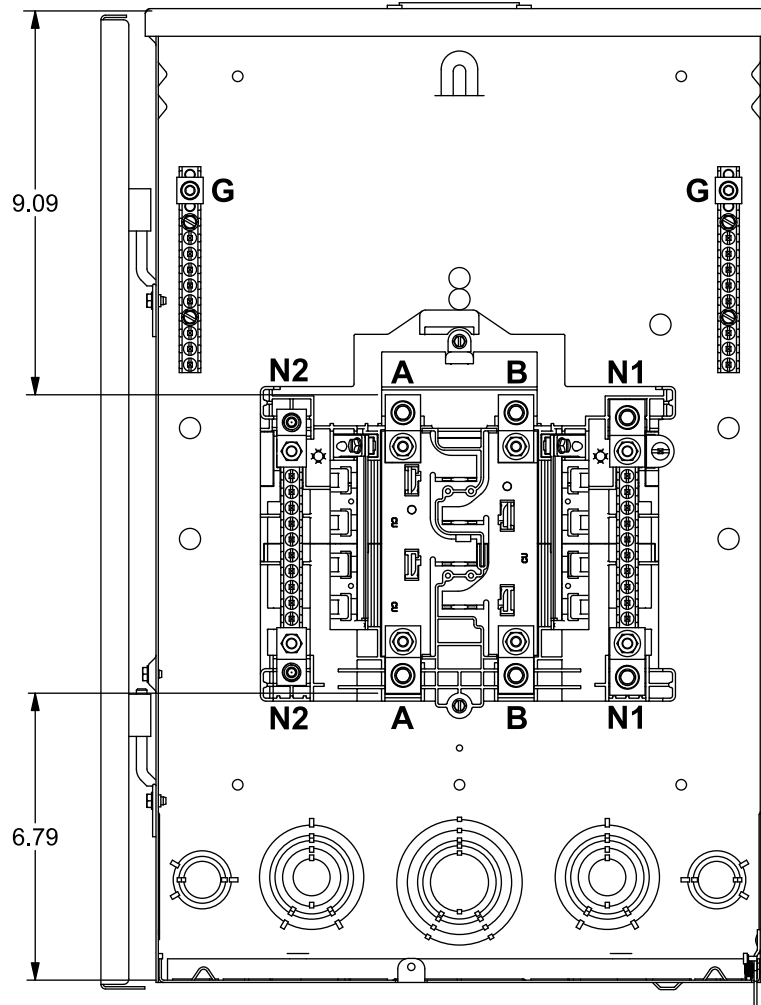
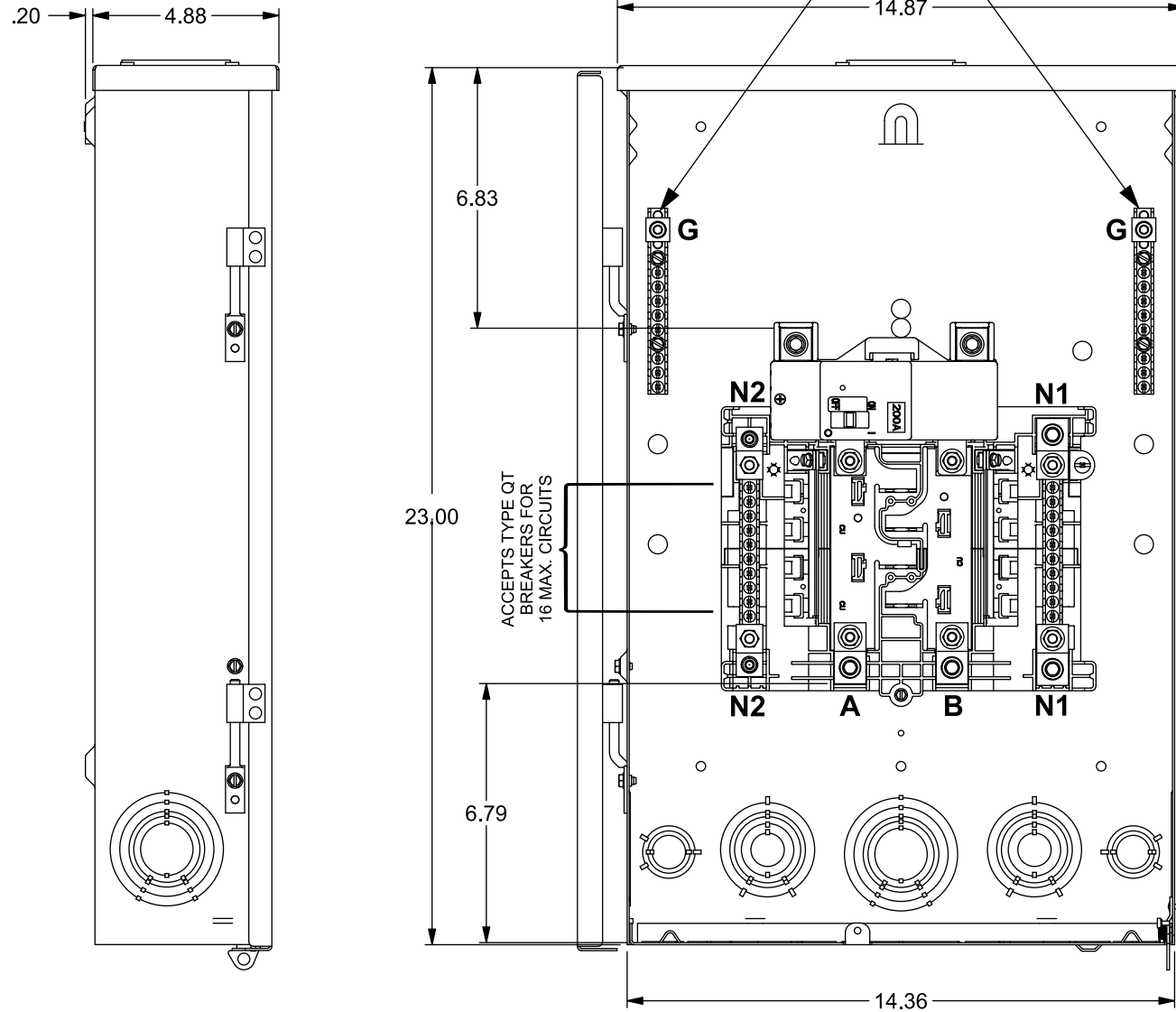

## Trim/Door Detail

Main Breaker Load Center Shown

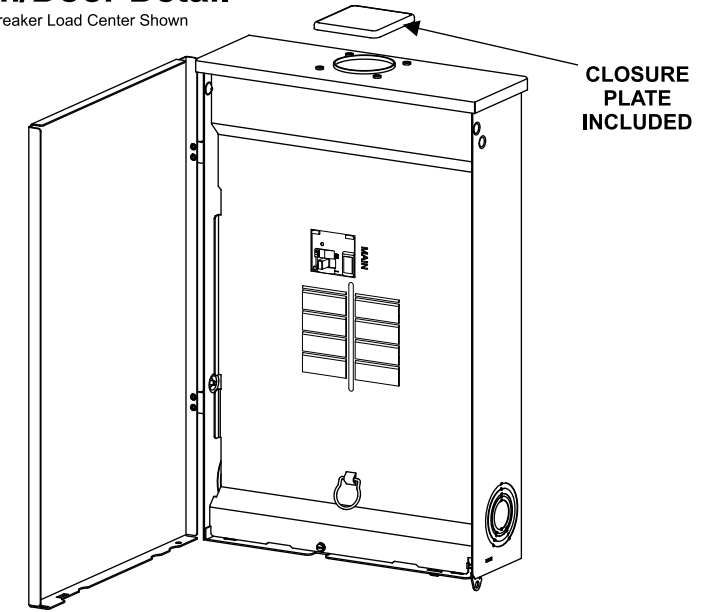

## KO Diagram

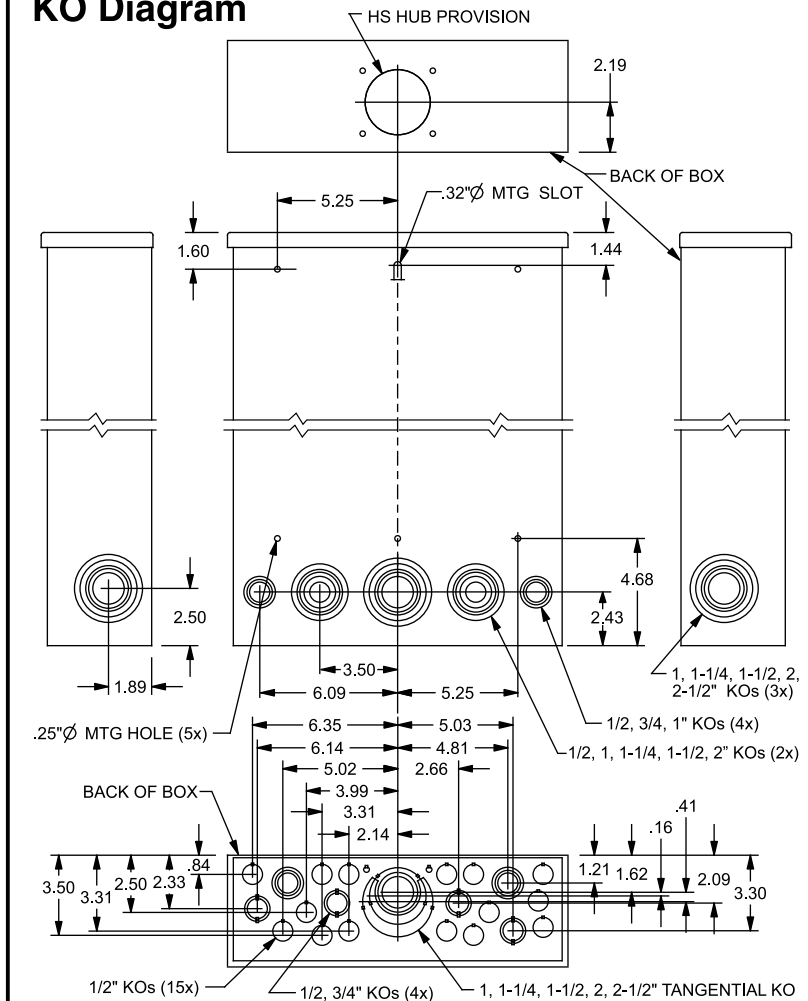

## TERMINAL WIRE SIZES AND TORQUES

USE COPPER OR ALUMINUM 60°/75°C WIRE  
SEE BREAKER MARKINGS FOR WIRE SIZE AND TORQUE REQUIREMENTS.

TERMINALS	WIRE	TORQUE
A, B, N1	300kcmil - 4 AWG	250 LB-INS
G, N2	2/0-4 AWG	110 LB-INS
MAIN BREAKER	3/0 AWG CU; 250 kcmil AL Max.	See Breaker
NEUTRAL/GROUND BARS (USE TYPE EC1GB, EC2GB or EC3GB GND BAR KIT ACCY)	10-14 CU/10-12 AL 8 AWG 6-4 AWG	20 LB-INS 25 LB-INS 35 LB-INS
GROUND CONDUCTORS ONLY	(2)or(3) 14 AWG (2) 12-10 AWG (2) 12-10 AWG	20 LB-INS 20 LB-INS 20 LB-INS
ECLK1-2 NEUTRAL LUG KIT	2/0-4 AWG	45 LB-INS
ECLK2 NEUTRAL LUG KIT	2/0-4 AWG	135 LB-INS
ECLK3 NEUTRAL LUG KIT	300 kcmil - 1 AWG	340 LB-INS
MAIN LUG/MAIN BRKR TO BUS CONNECTION (1/4-20 NUT)		45 LB-INS
BONDING SCREW		45 LB-INS

## ACCESSORIES

REFER TO WIRING DIAGRAM FOR CORRECT ACCESSORY USAGE

DESCRIPTION	CAT. NO.
FILLER PLATE, 1"	QF3
QP HOLD-DOWN/BARRIER	ECMBR2
QNR LINE TERMINAL BARRIER	ECLTB3
SUBFEED LUG KIT	ECLK2125 ECLK2225
ARC FLASH LABEL	ECAFL

### MAIN LUG / MAIN BREAKER KITS

DESCRIPTION	CAT. NO.
150 AMP MAIN BREAKER	MBK150A
200 AMP MAIN BREAKER	MBK200A
150-225 AMP MAIN LUG	ECMLK225

### CONDUIT HUBS

TRADE SIZE	CAT. NO.
1 INCH	ECHS100
1-1/4 INCH	ECHS125
1-1/2 INCH	ECHS150
2 INCH	ECHS200
2-1/2 INCH	ECHS250

### GROUND BAR KITS

DESCRIPTION	CAT. NO.
TYPE EC2GB KIT, 12 SCREWS	EC2GB12
TYPE EC2GB KIT, 12 SCREWS, 2/0 LUG	EC2GB122
TYPE EC2GB KIT, 15 SCREWS	EC2GB15
TYPE EC2GB KIT, 15 SCREWS, 2/0 LUG	EC2GB152
TYPE EC3GB KIT, 21 SCREWS	EC3GB21
TYPE EC3GB KIT, 21 SCREWS, 2/0 LUG	EC3GB212
TYPE EC3GB KIT, 27 SCREWS	EC3GB27
TYPE EC3GB KIT, 27 SCREWS, 2/0 LUG	EC3GB272
TYPE EC3GB KIT, 30 SCREWS	EC3GB30
TYPE EC3GB KIT, 30 SCREWS, 2/0 LUG	EC3GB302
TYPE EC3GB KIT, 35 SCREWS, 2/0 LUG	EC3GB352

© 2020 Copyright Siemens Industry, Inc.

**SIEMENS**  
Siemens Industry, Inc.

## Load Center

Description:  
**PN Series, 1 Phase, Outdoor, Feed-Thru, 200A, 8 Pos, 16 Ckt, Main Breaker/Lug**

KAM 4/29/20 DO NOT SCALE DRAWING Dwg No. **PNW0816B-L1200TC**