

RAFP 2025 Return Air Filter Plenum

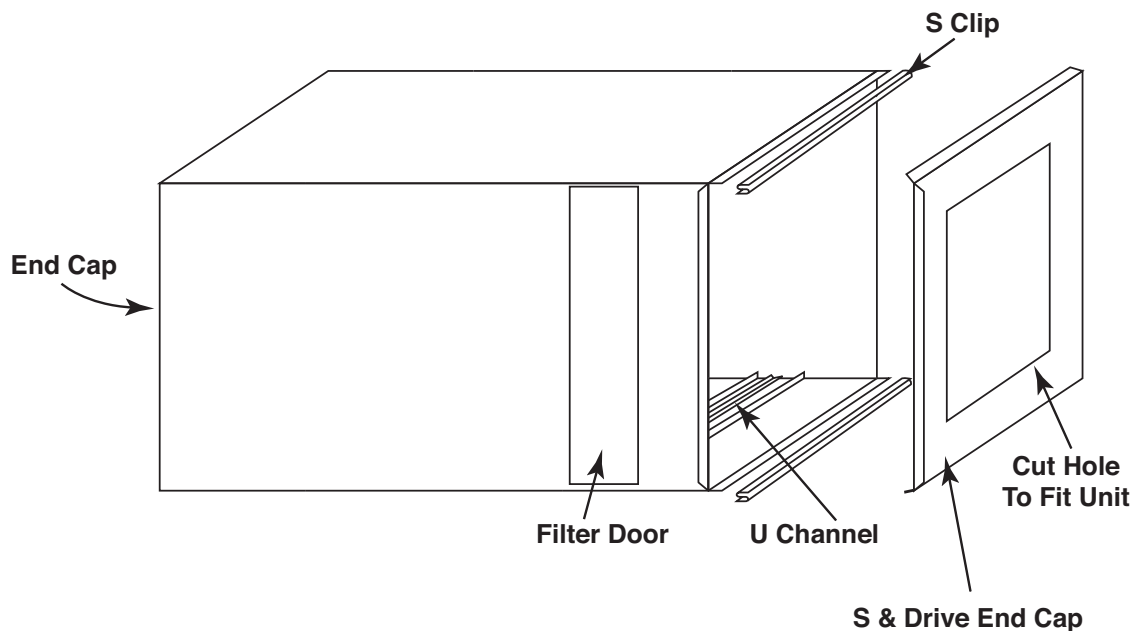

1. Cut hole in S & drive endcap to fit unit return air and attach to unit
2. Attach plenum to S & drive end cap using S's & drives provided
3. Install desired filter and door



Note: For 4" filter, remove U Channel Spacers.



Available in 2' or 3' lengths
Fits most furnaces & air handlers through 5 ton.