

WCR SERIES WATER COLLECTION & REMOVAL SYSTEMS

APPLICATIONS

Collection of sewage, effluent, drainage or seepage water

FEATURES

- Pre-packaged 20" x 30" (51 cm x 76 cm) polyethylene basin with 4/10 hp sewage pump
- Handles up to 2" (51 mm) solids
- Options of structural foam or steel covers
- Includes schedule 40 PVC discharge piping with pre-drilled air-bleed hole
- Designed with side outlets for discharge and electrical cords
- Includes 2" (51 mm) bulkhead fitting to easily route power cords out of basin
- Once installed, no digging required for system servicing
- cCSAus listed pump only



SERIES SPECIFICATIONS

Item No.	Model	Cover	Pump HP	Pump Performance
509081	WCR-9SP	Structural Foam	4/10	110 gpm @ 5' 416.4 lpm @ 1.5 m
509082	WCR-9SS	Steel	4/10	110 gpm @ 5' 416.4 lpm @ 1.5 m

Item No.	Model	Discharge	Check Valve	Cover	Pump HP	Volts	Pump Performance	Weight
509081	WCR-9SP	2" 51 mm	2" Slip x Slip	Structural Foam	4/10	115	110 gpm @ 5' 416.4 lpm @ 1.5 m	65 lbs 29.5 kg
509082	WCR-9SS	2" 51 mm	2" Slip x Slip	Steel	4/10	115	110 gpm @ 5' 416.4 lpm @ 1.5 m	69 lbs 29.5 kg

PUMP SPECIFICATIONS

Volts	Hz	Amps		Watts	Performance (GPM @ Height in Feet)			Shut-Off (ft)	PSI
		FLA	Start		5'	10'	15'		
115	60	8.5	17	850	110	70	30	20	8.7
208/230	50/60	4	7.5	800	110	70	30	20	8.7

Item No.	Model	HP	Volts	Discharge	Switch Type/ Operation	On Level	Off Level	Cord	Weight
509228	9SN-CIA-SFS	4/10	115	2"	Integral Snap-Action Float	9" - 12" 22.26 cm - 30.48 cm	3" - 6" 7.62 cm - 15.24 cm	20' 6.1 m	35.5 lbs 16.1 Kg
509204	9SN-CIA-RF	4/10	115	2"	Piggyback Mechanical Float	9" - 14" 22.86 cm - 35.56 cm	2" - 6" 5 cm - 15.24 cm	20' 6.1 m	35.5 lbs 16.1 Kg
509215	9SN-CIA-RF	4/10	115	3"	Piggyback Mechanical Float	9" - 14" 22.86 cm - 35.56 cm	2" - 6" 5 cm - 15.24 cm	20' 6.1 m	35.5 lbs 16.1 Kg
509226	9SN-CIM	4/10	115	3"	Manual	-	-	20' 6.1 m	35.5 lbs 16.1 Kg
509203	9SN-CIM	4/10	115	2"	Manual	-	-	20' 6.1 m	34.5 lbs 15.65 Kg
509217	9SN-CIM	4/10	208-230	2"	Manual	-	-	20' 6.1 m	36 lbs 16.33 Kg
509227	9SN-CIM	4/10	208-230	3"	Manual	-	-	20' 6.1 m	36 lbs 16.33 Kg

PACKAGE SYSTEMS

WCR SERIES - WATER COLLECTION & REMOVAL SYSTEMS

ENGINEERING DATA

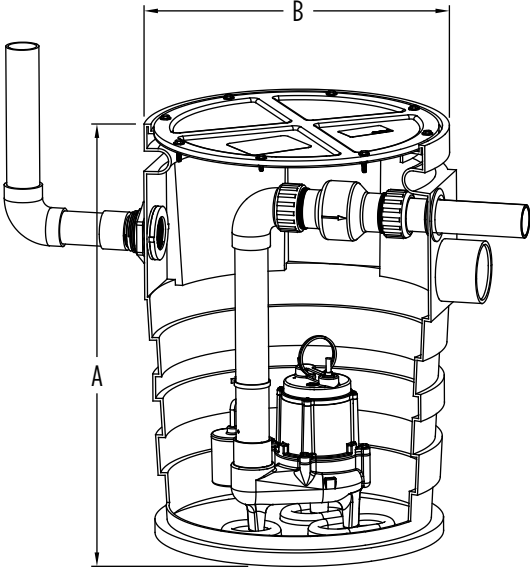

A	B
30"	22"
76.2 cm	55.88 cm

TYPICAL INSTALLATION

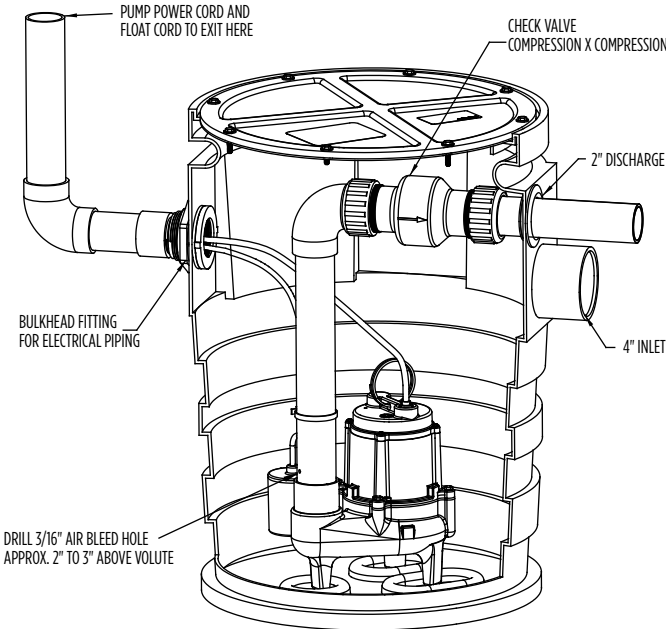

PERFORMANCE DATA

