

MOLDED

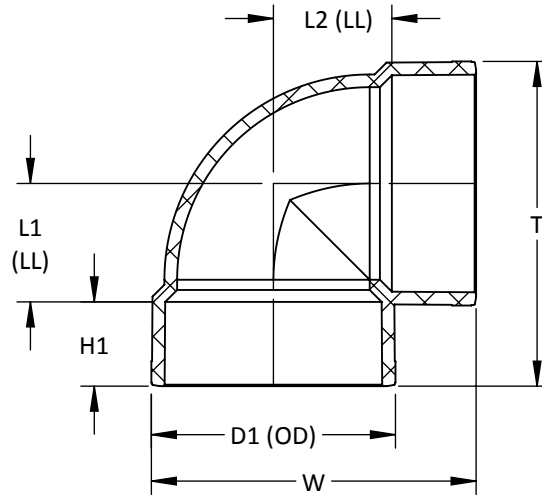

ASTM D2665, F1866, F2135, CSA B181.2 WHERE APPLICABLE

**1/4 BEND (90) VENT HxH
PVC SOLVENT WELD DWV**

PART NO.	SIZE IN INCHES	L1	L2	H1	T	W	D1
* D204	4	2 19/32	2 19/32	1 25/32	6 7/8	6 7/8	5 1/32
* D206	6	3 15/32	3 15/32	3 1/16	10 1/8	10 1/8	7 7/32
* D208	8	4 17/32	4 17/32	4 1/16	13 1/4	13 1/4	9 11/32
* D2010	10	6 7/16	6 7/16	5 1/16	17 1/4	17 1/4	11 17/32
* D2012	12	7 9/16	7 9/16	6 1/16	20 13/32	20 13/32	13 19/32

-- DIMENSIONS AND APPEARANCE ARE APPROXIMATE AND SUBJECT TO CHANGE
WITHOUT NOTICE DUE TO DESIGN OR PRODUCTION MODIFICATIONS
-- MOLDED FITTING TOLERANCE = ±1/8" OVERALL LENGTH
-- FABRICATED FITTING TOLERANCE = ±1" LINEAR, ± 2° ANGULAR

* MOLDED FITTING
† ASSEMBLED FROM MOLDED COMPONENTS
ALL OTHER FITTINGS ARE FABRICATED