

DFW39C-1-LID

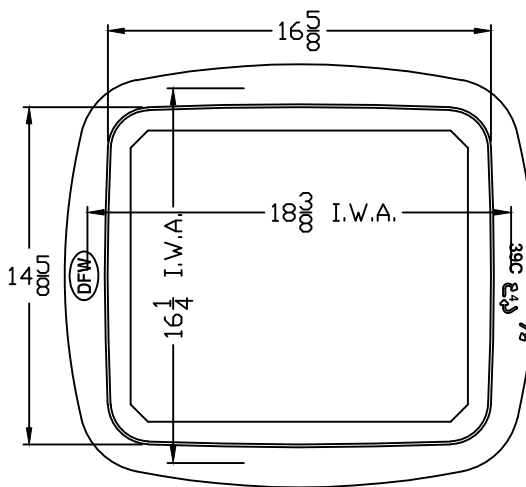

LID KEY	
1	BLACK COLOR



DFW39C-12-BODY

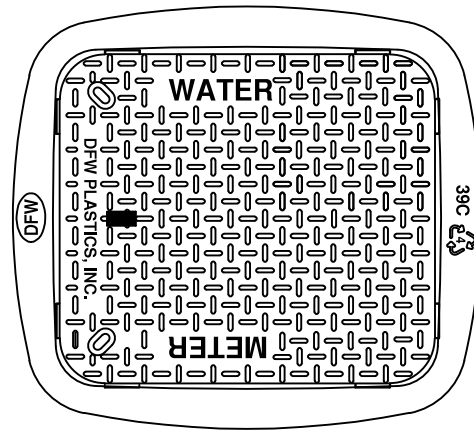

DFW39C-12-1

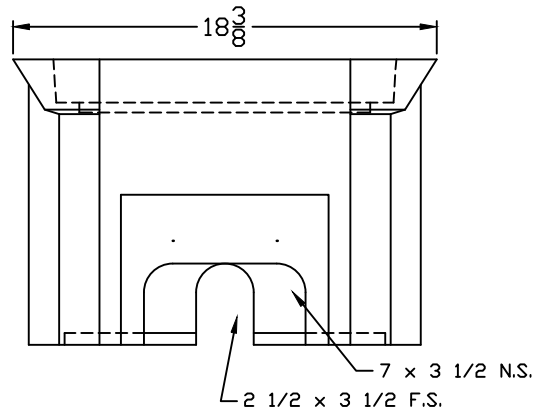
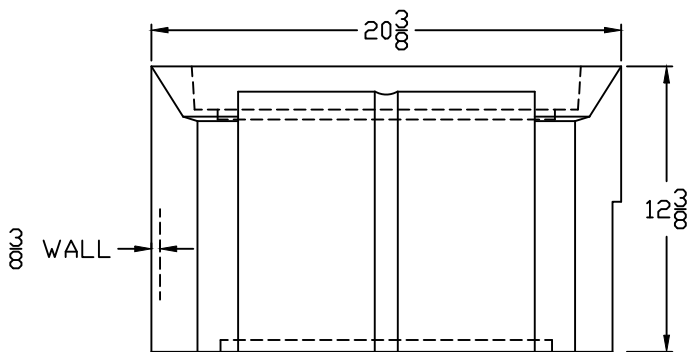

NOTES

- 1) DIM'S ± 1/8" U.N.O.
- 2) LID MATERIAL: HDPE
- 3) BODY MATERIAL: LLDPE
- 4) WALL THICKNESS: 3/8" ± 5%
- 5) I.W.A. = INSIDE WORK AREA

DFW PLASTICS, INC. ENGAGES IN ONGOING RESEARCH AND DEVELOPMENT TO IMPROVE AND ENHANCE ITS PRODUCTS. THEREFORE, DFW PLASTICS, INC. RESERVES THE RIGHT TO CHANGE PRODUCT OR SYSTEM SPECIFICATIONS WITHOUT NOTICE.



DFW PLASTICS, INC.
 PO BOX 648
 BEDFORD, TEXAS 76095
 (817) 439-3600
 (817) 439-3700 (f)
 www.dfwplasticsinc.com

DFW39C-12-1

CREATED:	07/03/2013
UPDATED:	07/03/2013
ACCEPTED:	JMc
DRAWN BY:	RMc
PLOT SCALE:	1:8